



A Review of Parameter Monitoring & Controlling System for Three Phase Induction Motor Using PLC & SCADA

Prof.A.P.Paranjape¹, D.B.Palamkar²

Assistant Professor, Dept. of Electrical Engg, P.E.S. Engineering College, Augangabad, Maharashtra, India¹

PG Student [EPS], Dept. of Electrical Engg, P.E.S. Engineering College, Augangabad, Maharashtra, India²

ABSTRACT: Now a days industries have gradually shifted from conventional relay logic control to intelligent programmable logic control. Three phase induction motors are mostly used AC motors in industry for various operations. Here the review of monitoring and control system for the induction motor based on programmable logic controller (PLC) & SCADA is described. Also the implementation of a hardware and software for speed control, direction control, parameter monitoring on SCADA screen and protection is provided. Variable Frequency Drives (VFD) can also be used to control the motor rotation direction and rotation speed of the three phase induction motor. All the required control and motor performance monitoring parameter data will be taken to a personal computer by SCADA Software Wonderware InTouch via PLC for further analysis.

KEYWORDS: PLC, SCADA, Induction motor, electric drives, performance parameters etc.

I.INTRODUCTION

Many factories use PLCs in automation processes to reduce production cost and to increase quality and reliability. In any industry the induction motor plays vital role due to its features like low cost and simplicity. By designing a monitoring control system for the speed of motor, the induction motor can be used in high performance variable-speed applications. To control the speed of such motor, a motor drive and control system with different methods can be used. Here we present a PLC-based monitoring control system for a three-phase induction motor. It describes the design and implementation of the configured hardware and software. Synchronous speed given by $N_s = (120 * F) / P$ Where, F= supply frequency, P= no.of poles Synchronous speed is directly proportional to the supply frequency. Hence, by changing the output frequency, the synchronous speed and motor speed can be control below and above the normal full-load speed. For this now a days the variable frequency drive is using. The traditional variable-frequency drive (known as volts per hertz (V/Hz) changes the motor's frequency and voltage using solid-state control units. The modern strategy for controlling the AC output of such a power electronic converters is the technique known as Pulse Width Modulation (PWM), which varies the duty cycle of the converter switches at a high switching frequency to achieve a target average low frequency output voltage or current, SCADA is an important application that allows a operator to monitor and control processes that are distributed among various remote sites.

II.LITERATURE SURVEY

As per Zhang P, in various systems or process control system mostly electrical motors are used, especially the induction motors, because of their suitability in system design in industry and many other advantages like energy, time, and sensitivity [1]. In research work of ChaitanyaN. Jibhakate and Mrs.VijayaHuchcheinvestigates the speed control performance of single-phase induction motor using microcontroller. The complete design is modelled and tested using MATLAB simulation and hardware implementation to control the speed. Single phase induction motor has been control by frequency And Voltage control method by using SPWM control circuit and H-bridge inverter [2] As per Shweta hugar, Basavaraj Amarpurto protect an Induction motor easily, a microcontroller based fault detection and protection of Induction motor proposed. This system tends to develop for protection of three phase induction motor

International Journal of Advanced Research in Electrical, Electronics and Instrumentation Engineering

(An ISO 3297: 2007 Certified Organization)

Website: www.ijareeie.com

Vol. 6, Issue 2, February 2017

from over voltage and under voltage, over current, over speed, temperature, Line frequency and phase failure with their sensing circuits[3] Mahendra Bodkhe & K N Pawar explains Parameter monitoring of an induction motor by Zigbee protocol. Zigbee is mostly used in industries in various ways because it supports devices having low cost, intelligent network topologies and energy saving[4] Snehal Lande, Pooja Jaiswal, Priyanka Rajgure used GSM Technology for Protection of induction motor against possible problems such as overvoltage , overcurrent , overspeed , overtemperature , three-phase unbalanced occurs in course of it's operation. Experimental results shows that the parameters of induction motor can be monitored using GSM which costs less, provides higher accuracy as well as safe and motorgets fully protected.[5] Arfat Siddique, G.S.Yadava and Bhim Singhdefine various techniques used to monitor faults in an induction motor.These techniques can be classified into the following categories using different parameters like Temperature, Magnetic flux, Vibration, Power, Current, Induced voltage, Instantaneous Angular speed, Air-Gap Torque, Partial discharge, Surge current, Gas analysis, Motor circuit analysis, Stator Current Monitoring, Visual monitoring.[6] Alberto Bellini, Fiorenzo Filippetti, Carla Tasoni, And Gerard-Andre Capolino classify diagnosis procedure for an induction motor into three classes as model based, signal based & data based[7] A R Al-Ali et al. proposed a power factor controller for a three-phase induction motor using PLC to improve the power factor of a three-phase induction motor[8]

Because of noisy surrounding, critical environmental condition like excessive temperature, humid weather etc. sometime microcontroller are not suitable for industrial environment, microcontroller may fail in its operation. With the use of GSM based parameter monitoring system, it was possible to observe motor status on Mobile screen, but it is not possible to keep record of all parameter with respect to time. The Signal Processing based approach of fault diagnosis may not effective in online condition monitoring of an induction motor.

But the use of a PLC can be the right choice if it is considered in an automation system in order not to use extra microprocessor. Nowadays, the most widely used area of PLC & SCADA based system is the control circuits of industrial automation systems.

III. OVERVIEW OF PROPOSED WORK METHODOLOGY

The draw backs of the previous work are sometime microcontroller not suitable for industrial environment, motor parameters were not possible to show on PC and motor control from PC was not possible.

In proposed work we design a system that is to monitor motor parameter on SCADA Screen. This system configuration of parameter monitoring of an induction motor system is shown in figure 3.1. This system consists of different working arrangements which mainly consist of induction motor, current sensor, VFD, PLC and PC and figure shows the detail blocks which describes the working of the parameter monitoring of an induction motor system. As seen from above figure Induction motor is last element whose parameter we have to monitor on SCADA. Induction motor receives AC main power through AC Drive or VFD. To see current consumed by an induction motor on SCADA screen, we use CT which is connected in between motor and PLC. Output of CT is given to PLC through which value of current is shown on SCADA screen. VFD plays vital role in protecting motor from various faults like overload, overvoltage, over current, etc. Whenever faults occur, VFD indicates the same on its display. By referring code user will be able to find solution same within a short period of time. Here the system is set to sense motor parameters, to show them on SCADA screen also to control motor from SCADA. Once the parameters are sensed, PLC will decide whether measured parameters are within limit or not. If the parameter crosses the limit set by user, SCADA screen will give warning message on its screen. So at supervisory level, user will be able to see motor condition, its parameters whether they are crossing threshold or not. User also will be able to control motor.

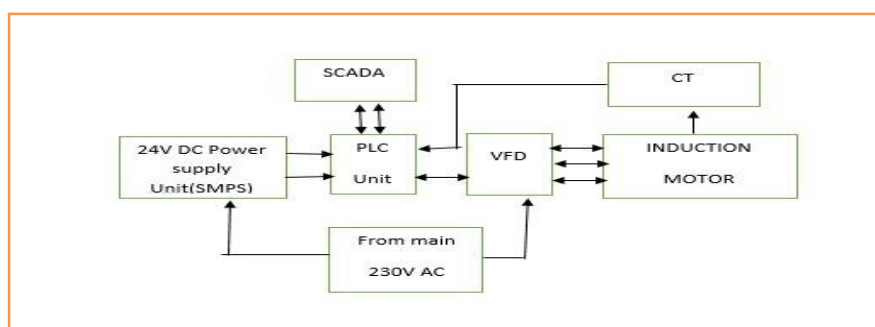



International Journal of Advanced Research in Electrical, Electronics and Instrumentation Engineering

(An ISO 3297: 2007 Certified Organization)

Website: www.ijareeie.com

Vol. 6, Issue 2, February 2017

A. PLC UNIT

Here for controlling operation of induction motor, that suits system requirement, we have to develop logic. It is also necessary to take motor parameters as an input and to send them as an output to SCADA system along with decision making capabilities. Hence we use Allen Bradley PLC with following specifications given in table 3.1

Model	Micrologix-1200
Series	C
Maker	Allen Bradley
Input/output (Digital)	14/10
Input/output (Analog)	4/0
Supply Voltage	24 volts Dc

Table 3.1 PLC Specifications

C. VFD UNIT/ ELECTRICAL DRIVE SYSTEM:

In this system we require to handle high power devices operating electronically to control and protect the induction motor and we also require high input to the VFD. A VFD is useful for applications wherein speed control is of an essential importance due to load changes wherein the speed needs to be increased or decreased accordingly. To provide these requirements we used VFD with the specification of the VFD as shown table 3.2

Model	Powerflex 40
Series	A
Maker	Allen Bradley
Input Frequency	50 Hz
Rated Power	0.5 Hp

Table 3.2: VFD Specification

The output parameters from the motor and PLC input requires a proper isolation that means the proper range of the voltage. Hence to provide the isolation between PLC control circuit and high voltage motor, motor control and protection, VFD is used. A Variable Frequency Drive (VFD) is a type of motor controller that drives an electric motor by varying the frequency and voltage supplied to the electric motor. Other names for a VFD are variable speed drive, adjustable speed drive, adjustable frequency drive, AC drive, microdrive, and inverter. VFDs are used in applications ranging from small appliances to the largest of mine mill drives and compressors. VFD system basically consist of three main sections namely, Converter, DC Bus & Inverter. Converter section converts AC mains into DC, DC Bus that further rectifies and carries dc signal and finally Inverter section which again converts DC to AC but in PWM form.

C. SCADA SYSTEM

The main purposes for the use of a SCADA system would be to collect the needed data from remote sites and even the local site, displaying them on the monitor of the master computer in the control room, storing the appropriate data to the hard drive of the master computer and allowing the control of field devices (remote or local) from the control room. SCADA stands for Supervisory Control and Data Acquisition. SCADA refers to a system that collects data from various sensors at a factory, plant or in other remote locations and then sends this data to a central computer which then manages and controls the data. SCADA is a term that is used broadly to portray control and management solutions in a wide range of industries. One of key processes of SCADA is the ability to monitor an entire system in real time. SCADA systems are equipped to make immediate corrections in the operational system, so they can increase the life-period of your equipment and save on the need for costly repairs. It also translates into man-hours saved and personnel enabled to focus on tasks that require human involvement

International Journal of Advanced Research in Electrical, Electronics and Instrumentation Engineering

(An ISO 3297: 2007 Certified Organization)

Website: www.ijareeie.com

Vol. 6, Issue 2, February 2017

IV. SOFTWARE DESCRIPTION

Under the IEC 61131-3 standard, PLCs can be programmed using standards-based programming languages. A graphical programming notation called Sequential Function Charts is available on certain programmable controllers. Initially most PLCs utilized Ladder Logic Diagram Programming, a model which emulated electromechanical control panel devices (such as the contact and coils of relays) which PLCs replaced. This model remains common today. The developed ladder logic is shown in figure 4.1. Power flows through these contacts when they are closed. The normally open (NO) is true when the input or output status bit controlling the contact is 1. The normally closed (NC) is true when the input or output status bit controlling the contact is 0.



Figure 4.1: Ladder Diagram

V. RESULTS & CONCLUSION

In this project, the monitoring and control system is designed for three phase induction motor. It is concluded that proposed system is feasible method for controlling of an induction motor. With the use of PLC & SCADA, the control system is more reliable. The control system design is based on most advanced technology which give high amount of flexibility and efficiency. Monitoring system give facility of analysing the operation of an induction motor in online/offline mode which make the system to be safe from fault/error conditions

REFERENCES

- [1]Zhang P., Du Y., Habetler TG, Lu B., —A Survey of Condition Monitoring and Protection Methods for Medium-Voltage Induction Motors, IEEE Transactions On Industry Applications, 47 (1): 34-45 (2011)
- [2]Chaitanya N. Jibhakate and Mrs. Vijaya Huchche “Speed Control of Single Phase Induction Motor Using Micro-Controller” IJERA pp.29-32 April 2014
- [3]Shwetahugar, Basavaraj Amarapur “Protection of Induction Motor using Microcontroller” IJETAE, Volume 6, no. 5, pp. 64-68, May 2016
- [4]Mahendra P. Bodkhe and K. N. Pawar “Parameter Monitoring Using Zigbee Protocol for Three Phase Induction Motor ” IJETAE, Vol.4, no.1, pp. 73-77, January 2014
- [5]SnehalLande, PoojaJaiswal, PriyankaRajgure “An analytical approach of Parametric Monitoring of Induction Motor Using GSM”, IOSRJECE Volume 1, no.3, PP.01-07, May-June 2012
- [6] Arfat Siddique, G.S.Yadava and Bhim Singh, “A review of stator fault monitoring technique of induction motor”, IEEE transaction on energy con. Vol20, Mar2005.



ISSN (Print) : 2320 – 3765
ISSN (Online): 2278 – 8875

International Journal of Advanced Research in Electrical, Electronics and Instrumentation Engineering

(An ISO 3297: 2007 Certified Organization)

Website: www.ijareeie.com

Vol. 6, Issue 2, February 2017

- [7]Alberto Bellini, FiorenzoFilippetti, Carla Tasoni, And Gerard-Andre Capolino, "Advances in diagnostic techniques for induction motor", IEEE transaction on industrial electronics, vol55,Dec2008
- [8]A. R. Al-Ali, M. M. Negm, and M. Kassas, "A PLC based power factor controller for a 3-phase induction motor" in Proceedings of Conference Records IEEE Industry Applications, vol. 2, pages 1065–1072, 2000
- [9]S. Da'na, "Development of a monitoring and control platform for PLC-based applications" Journal Computer Standards & Interfaces, Vol. 30, Issue 3, pages 157-166, March 2008
- [10]N. D. Ramesh, "Programmable Logic Controllers and SCADA" Seminar Projects, March 2012
- [11]William J Weber, Robert M Cuzner, Eric Ruckstadter, Jim Smith, "Engineering fundamentals of multi-MW Variable Frequency Drives" Proceedings of the thirty-first Turbomachinery Symposium, pages 177-194,2002
- [12]Patrick A. Brady, "Application of AC motors with variable speed drive,"IEEE, Vol.89, 978-1-4245, 2009